

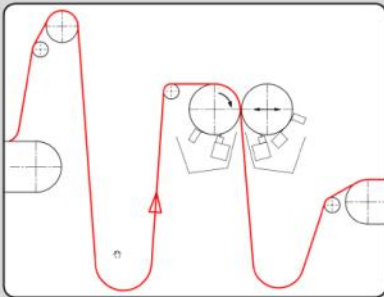

SUPRAPRESS.PENETRATION ENHANCER TO MINIMIZE DYE PICK-UP AT MAXIMUM PENETRATION



BASICS

In digital textile and carpet printing we want to achieve minimum ink and dye consumption at maximum penetration - especially on pile products.

SUPRAPRESS.FUNCTION

The dye and ink are squeezed into the pile by two rollers either at a constant gap (for high pile products) or using a constant pressure (for low pile and flat products). To avoid ghost stamping and printing effects the rollers are cleaned and dried very efficiently, using a combination of scrapers and wipers. The **SUPRAPRESS** is installed directly behind the printing unit, ahead of steamer or dryer. In case of polyester carpet or polyester blanket printing it is a must to use the **SUPRAPRESS** system to minimize pick-up and drying time and to maximize penetration.

- Little space needed - can be elevated or on ground floor between printer and steamer or dryer
- Can work with constant gap or at constant pressure
- Amount of pick-up can be reduced by about 80% (in comparison to "normal" **CHROMOJET** printing) - saves thickener, chemicals and energy
- Maximum penetration also on high pile products
- No frosting - undyed fibres are dipped into the dye
- No smearing or ghost printing - rollers are washed and dried continuously
- Minimum maintenance required
- Available for **CHROMOJET** as well as for **COLARIS** digital printing systems



76 dpi print before pressing

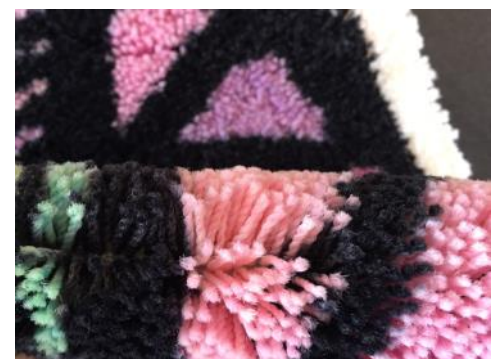

76 dpi print after pressing

APPLICATION

- To reach full penetration on high pile products (like Mink blankets, shaggy type carpets, ...) printed with **CHROMOJET** process colors
- Enhances penetration and evenness on **COLARIS.INKJET** prints on tufted and woven carpets, needle-felt products, polar and coral fleece products, terry towels, ...
- In combination with **CHROMOJET** polyester printing - to minimize dye pick-up
- To avoid frosting on printed monofilament products
- To get full penetration and even coloration when carpet or blankets are dyed using **CHROMOJET**

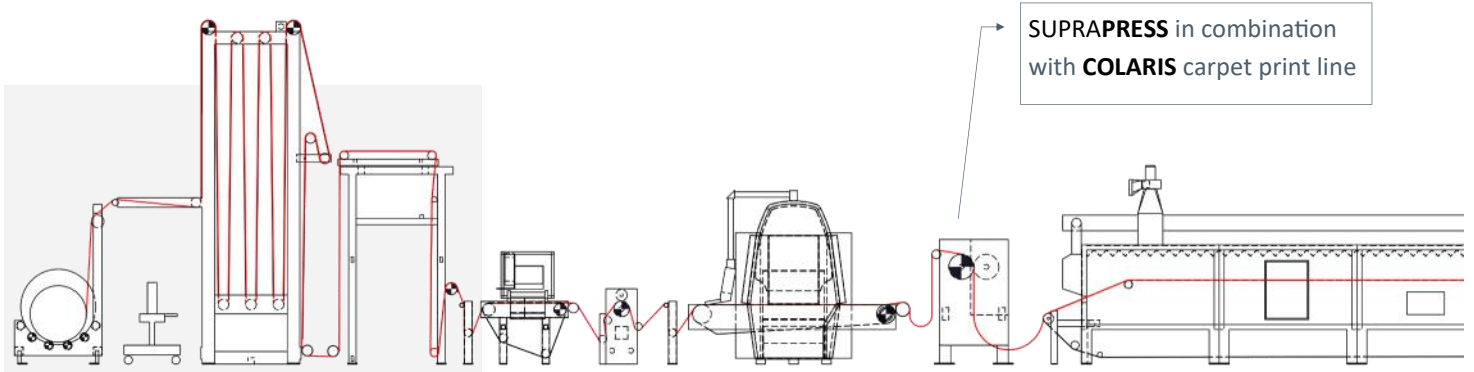

SUPRAPRESS	Sample unit		SUPRAPRESS production units				
Roller width (diameter is 400 mm)	1,300	2,400	2,400	2,800	3,600	4,400	5,400
Max. product width (mm)	1,200	2,200	2,200	2,600	3,400	4,200	5,200
Approx. water usage per hour at 1 bar	N/A		0.5 m ³	0.6 m ³	0.7 m ³	0.9 m ³	1.1 m ³
Drive	0.55 kW		0.9 kW at max. 10 m/min				
Roller cleaning	1-stage cleaning		<ul style="list-style-type: none"> • 3-step cleaning for the chromium plated pile side roller • 2-step cleaning for the rubber coated back side roller 				
Options	N/A		<ul style="list-style-type: none"> • Fixed or driven spreading roller for fleece products • Bow roller for backed carpet • Center guiding spreading roller • Integrated synchronization with loop detection • Water circulation system with filter and pump 				

Zimmer Maschinenbau GmbH
 DIGITAL PRINTING SYSTEMS
 Eibergstrasse 2-8
 6330 Kufstein | AUSTRIA
 Phone +43 (5372) 648 93 - 0
 info@zimmer-austria.com

INNOVATION

QUALITY

SERVICE

J. ZIMMER Maschinenbau GmbH, Kufstein reserves the right of technical and design modification of the equipment described within this brochure at any time without prior notice. This leaflet is for informative purpose only.